

# Montageanleitung Assembly Instructions

## V064.8

### Schiebetür 2-teilig „Vario“ / 2-part sliding door „Vario“

R: Fixteil rechts, dargestellt / Fixed part right, shown  
(L: Fixteil links, gespiegelt / Fixed part left, mirrored)

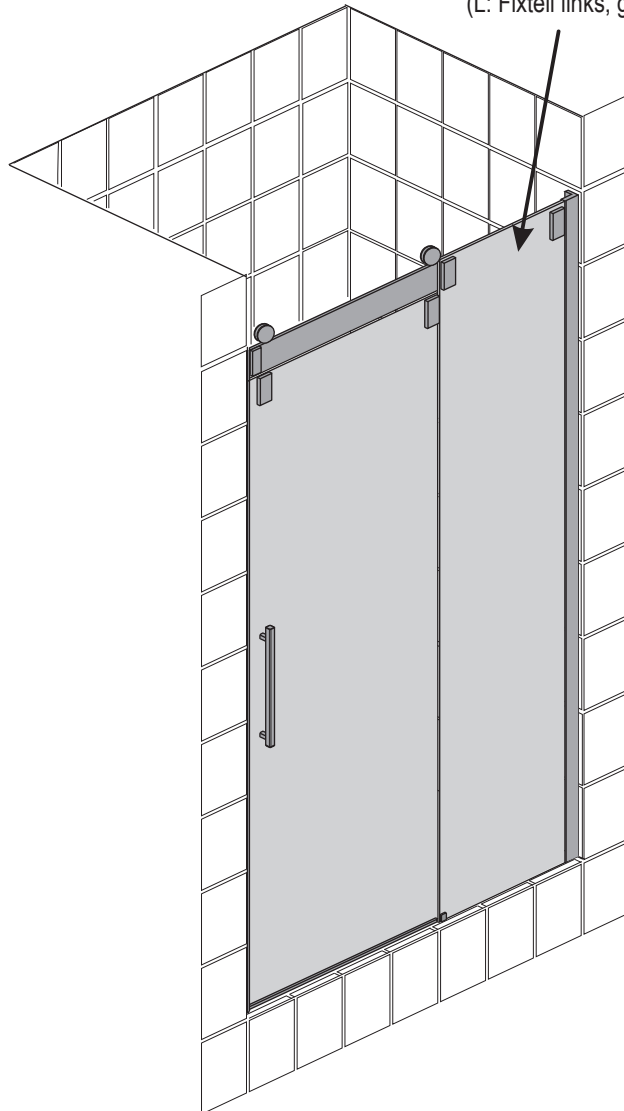



Vor Gebrauch sorgfältig lesen!  
Read carefully before use!

Diese Unterlage ist für den Endkunden!  
This document is for the end customer!

1 x 105042    4 x ø6 106537    4 x ø4,8x60 106882    4 x M5 103967

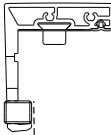
**1**  **Übrig bleibende Montagebauteile möglich. / Remaining assembly components possible.**

**1.1**  Bündig/Flush

**1.2**  ø6 mm TX25





8 mm

1 x R (1 x L)    3 x 105978    3 x M6x14 102095    1 x 106546    1 x 0,5 106671    1 x 1 106672

**2**

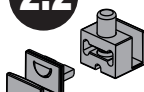
**2.1**  0,5 / 1 mm

**2.2** 

**2.3**  SW4

**2.4** 

**3**

**3.1** 

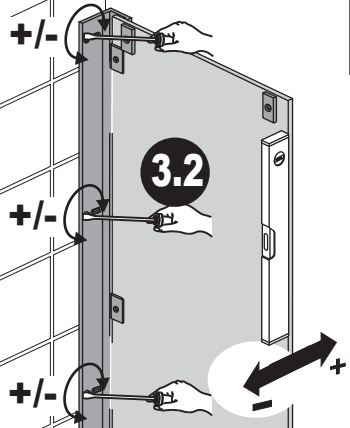
**3.2**  +/-

**3.3** 

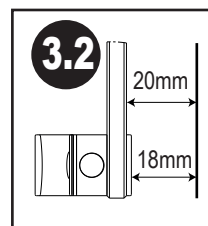
**3.2**  20mm 18mm

1 x 104949    5 x ø6 106537    5 x ø4,2x50 106538    3 x M4 101385    1 x 106340

**4**

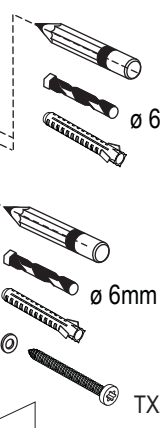
 ø6 mm TX20

44 mm

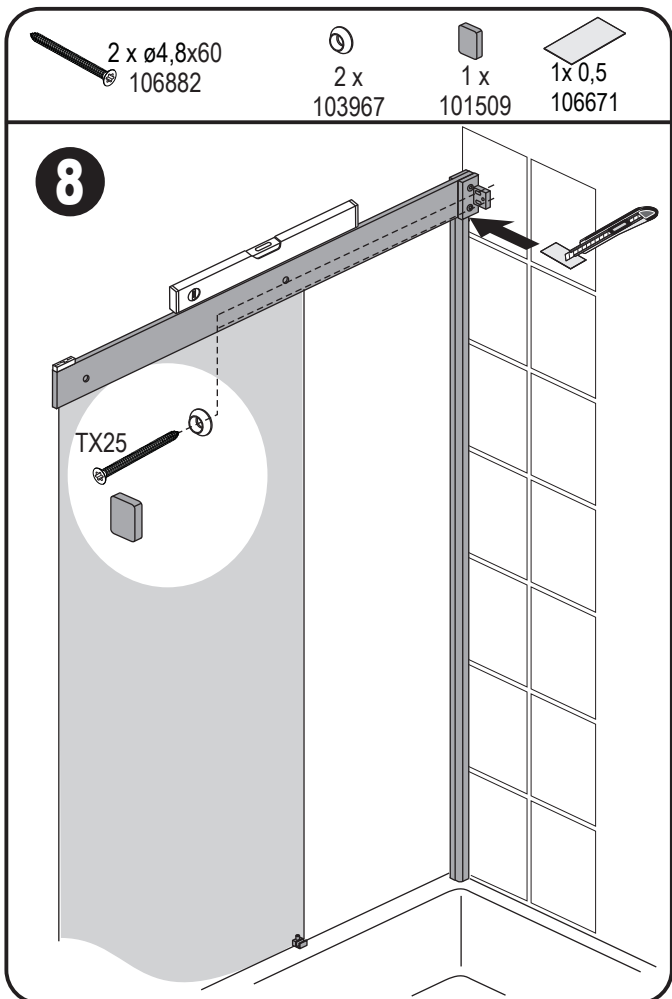
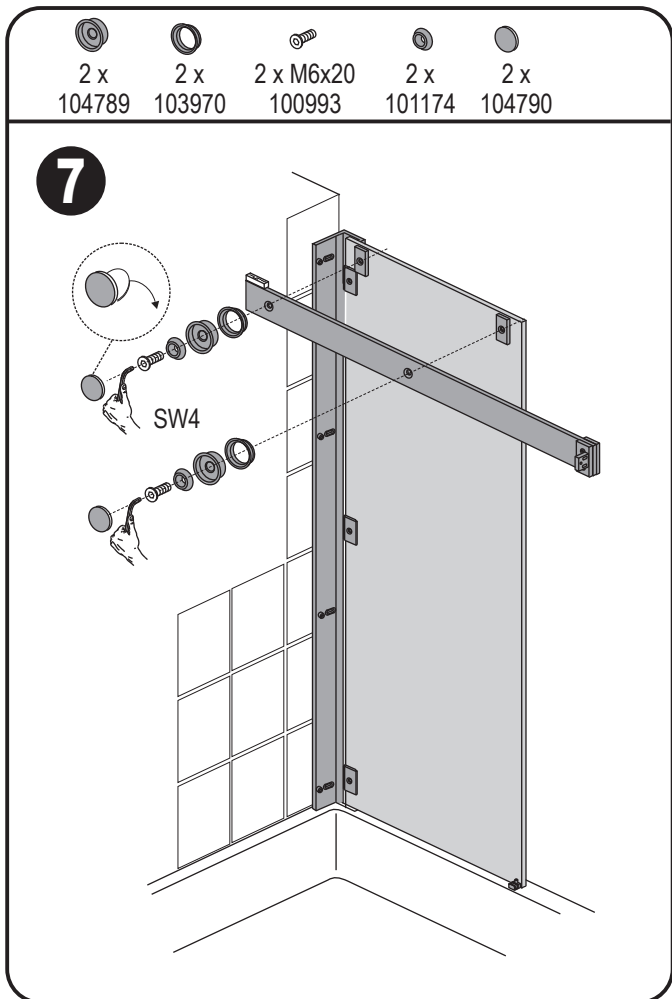
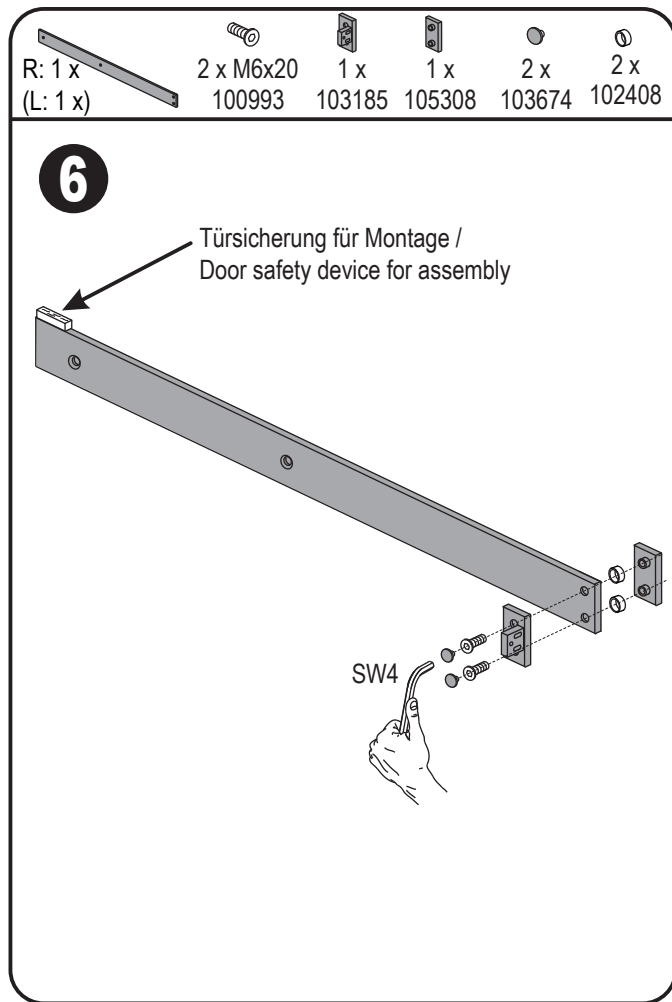
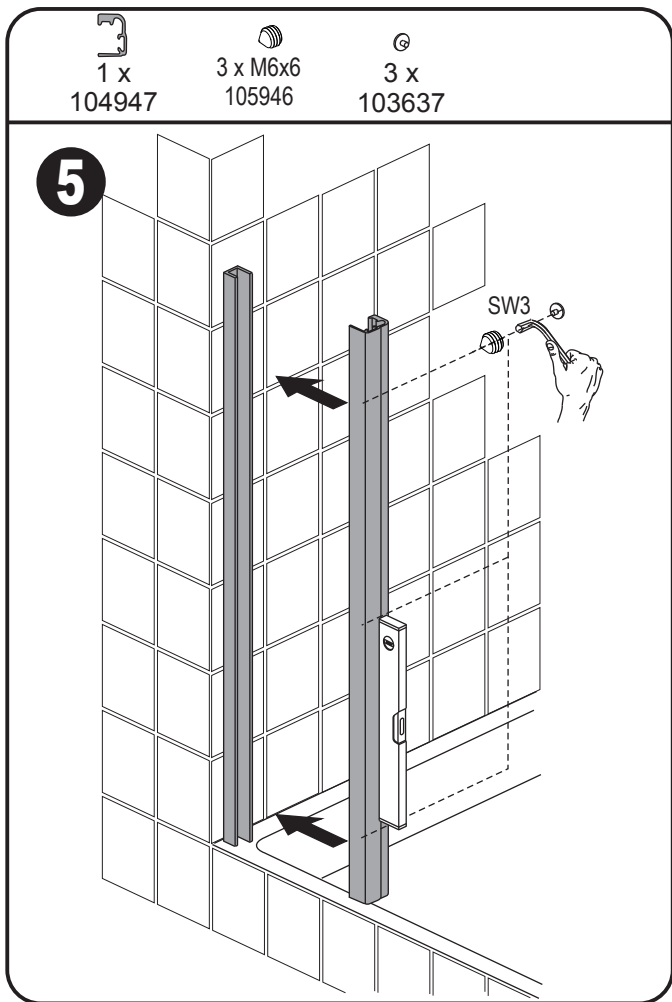

- 1 x 104836
- 2 x 106170
- 2 x 106169
- 1 x
- 4 x M6x22 106293
- 4 x 102408
- 4 x 103674
- 1 x 106343
- 1 x 106342
- 1 x 107200

**9**

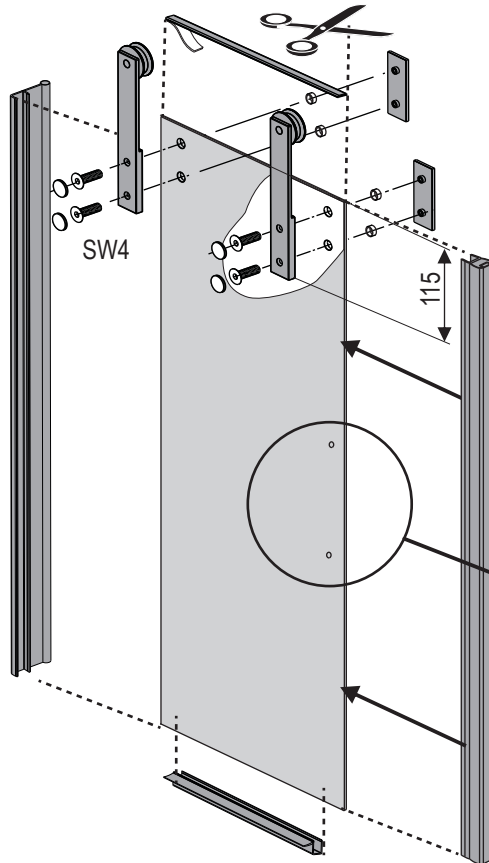

Oberkante Glas muss immer geschützt sein! Bruchgefahr!!! / Upper glass edge need to be covered always! Risk of breaking!!!



Rollenhalter in regelmäßigen Abständen kontrollieren !!! / Check roller holders at regular intervals !!!

**10**

**Griffmontage / Handle mounting**

**11**

**11.1**

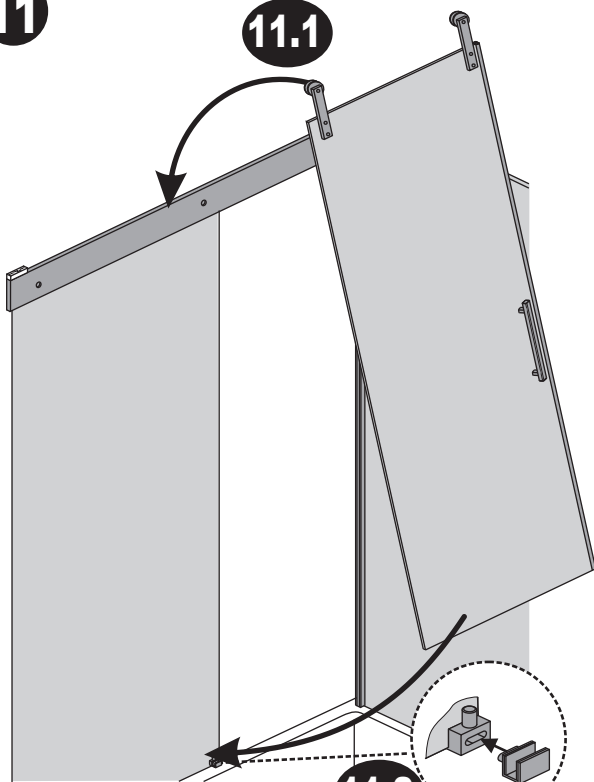

**11.2**

**12** OPTION

- 1 x 103813

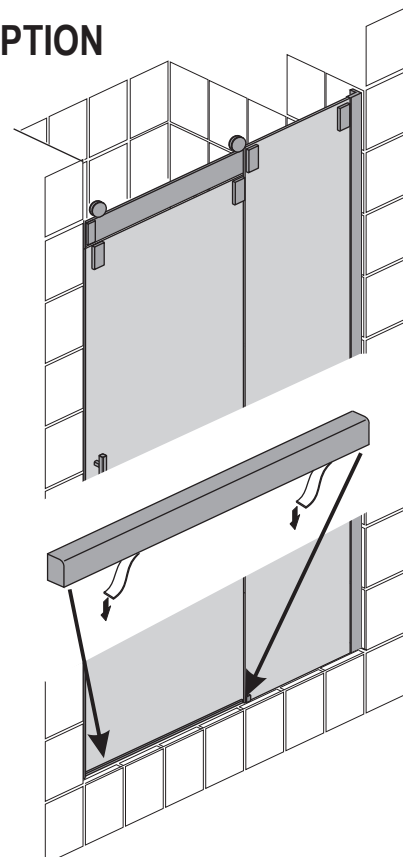

Für den entsprechenden Untergrund geeignetes Silikon verwenden.  
 Oberfläche vor dem Silikonieren gründlich reinigen (fettfrei).  
 Use suitable silicone for the respective base material.  
 Thoroughly clean the surface prior to using silicone.



**14**

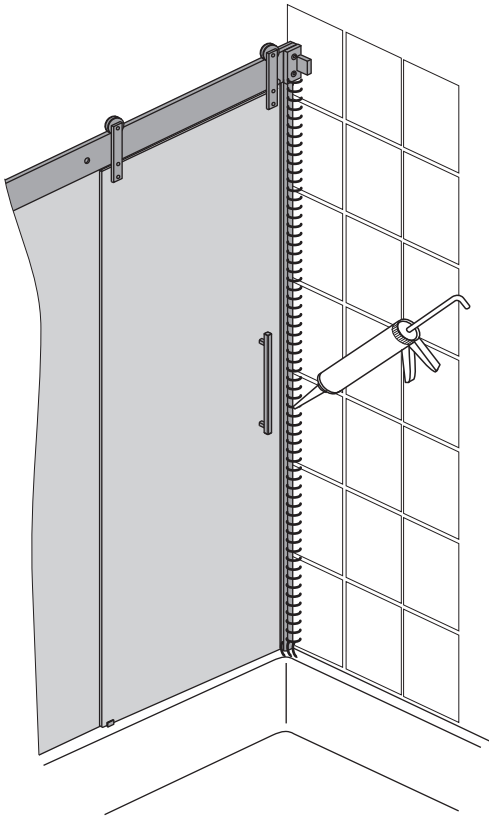

R: 1 x 105781  
 (L: 1 x 105780)

1 x 105043 R  
 (1 x 105043 L)

1 x 105269

1 x 106217

**15**

**15.5**

**15.3**

**15.6**

**15.1**

**15.4**

**15.2**

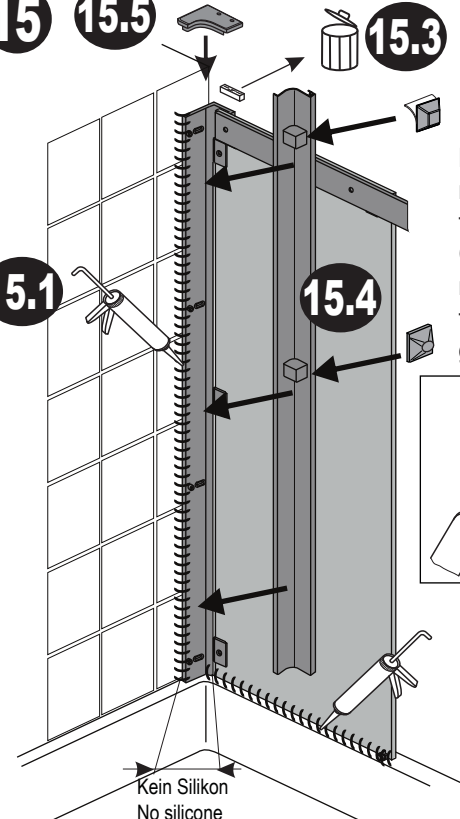

Klebefläche muss staub- & fettfrei sein ! /  
 Glue surface must be free from dust and grease!

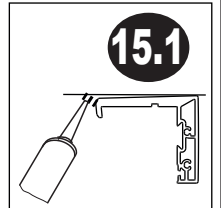

Kein Silikon  
 No silicone

**16**

